

Keysight Technologies

HMMC-3104 DC-16 GHz Packaged Divide-by-4 Prescaler

1GC1-8202-TR1-7" diameter reel/500 each

1GC1-8202-BLK-bubble strip/10 each

Data Sheet

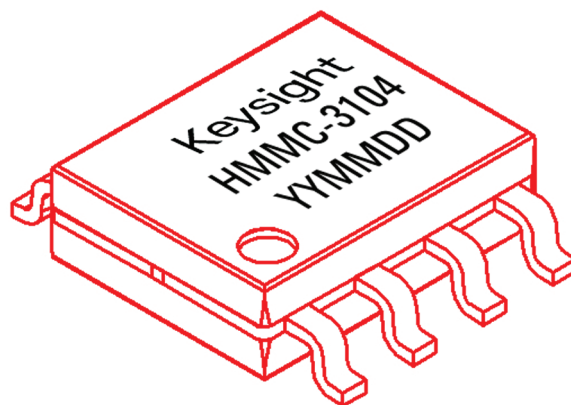

Features

- Wide frequency range:
0.2 - 16 GHz
- High input power sensitivity:
On-chip pre- and post-amps
 - 20 to +10 dBm (1 - 10 GHz)
 - 15 to +10 dBm (10 - 12 GHz)
 - 10 to +5 dBm (12 - 15 GHz)
- P_{out} : +6 dBm (0.99 V_{p-p})
will drive ECL
- Low phase noise:
-153 dBc/Hz @ 100 kHz offset
- (+) or (-) Single supply bias
with wide range: 4.5 to 6.5 V
- Differential I/O with on-chip
50 Ω matching

Description

The Keysight Technologies, Inc. HMMC-3104 is a packaged GaAs HBT MMIC pre-scaler which offers dc to 16 GHz frequency translation for use in communications and EW systems incorporating high-frequency PLL oscillator circuits and signal-path down conversion applications. The prescaler provides a large input power sensitivity window and low phase noise.

Absolute maximum ratings¹

(@ $T_A = 25\text{ }^\circ\text{C}$, unless otherwise indicated)

Symbol	Parameters/conditions	Min	Max	Units
V_{CC}	Bias supply voltage		+7	volts
V_{EE}	Bias supply voltage	-7		volts
$V_{CC}-V_{EE}$	Bias supply delta	0	+7	volts
V_{Logic}	Logic threshold voltage	$V_{CC} - 1.5$	$V_{CC} - 1.2$	volts
$P_{in(CW)}$	CW RF input power		+10	dBm
V_{RFIn}	DC input voltage (@ RF_{in} or RF_{in} ports)		$V_{CC} \pm 0.5$	volts
T_{BS}^2	Backside ambient temperature	-40	+85	$^\circ\text{C}$
T_{st}	Storage temperature	-65	+165	$^\circ\text{C}$
T_{max}	Max. assembly temperature (60 s max.)		310	$^\circ\text{C}$

1. Operation in excess of any parameter limit (except T_{BS}) may cause permanent damage to the device.
2. $MTTF > 1 \times 10^6$ hours @ $T_{BS} \leq 85\text{ }^\circ\text{C}$. Operation in excess of maximum operating temperature (T_{BS}) will degrade MTTF.

DC specifications/physical properties¹

($T_A = 25\text{ }^\circ\text{C}$, $V_{CC} - V_{EE} = 5.0$ volts, unless otherwise listed)

Symbol	Parameters/conditions	Min	Typ	Max	Units
$V_{CC} - V_{EE}$	Operating bias supply difference ¹	4.5	5.0	6.5	Volts
$ I_{CC} $ or $ I_{EE} $	Bias supply current	68	80	92	mA
$V_{RFIn(q)}$, $V_{RFout(q)}$	Quiescent dc voltage appearing at all RF ports		V_{CC}		Volts
V_{Logic}	Nominal ECL Logic Level (V_{Logic} contact self-bias voltage, generated on-chip)	$V_{CC} - 1.45$	$V_{CC} - 1.35$	$V_{CC} - 1.25$	Volts

1. Prescaler will operate over full specified supply voltage range, V_{CC} or V_{EE} not to exceed limits specified in *Absolute maximum ratings* section.

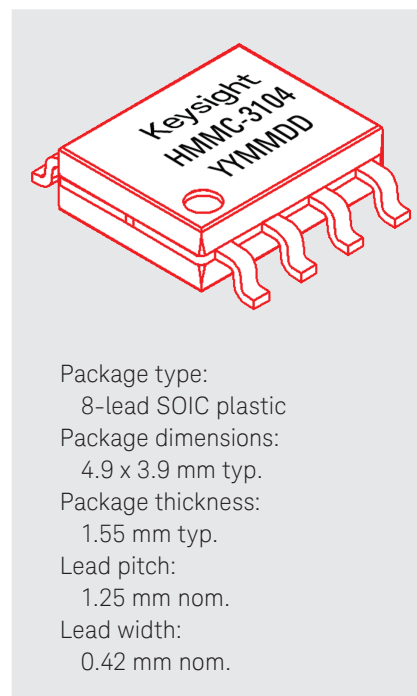

RF specifications

($T_A = 25\text{ }^\circ\text{C}$, $Z_0 = 50\ \Omega$, $V_{CC} - V_{EE} = 5.0\text{ volts}$)

Symbol	Parameters/conditions	Min	Typ	Max	Units
$f_{in(max)}$	Maximum input frequency of operation	16	18		GHz
$f_{in(min)}$	Minimum input frequency of operation ¹ ($P_{in} = -10\text{ dBm}$)		0.2	0.5	GHz
$f_{Self-Osc.}$	Output self-oscillation frequency ²		3.4		GHz
P_{in}	@ DC (Square-wave input)	-15	> -25	+10	dBm
	@ $f_{in} = 500\text{ MHz}$ (Sine-wave input)	-15	> -20	+10	dBm
	$f_{in} = 1\text{ to }10\text{ GHz}$	-15	> -25	+10	dBm
	$f_{in} = 10\text{ to }12\text{ GHz}$	-10	> -15	+10	dBm
	$f_{in} = 12\text{ to }15\text{ GHz}$	-4	> -10	+4	dBm
RL	Small-signal input/output return loss (@ $f_{in} < 12\text{ GHz}$)		15		dB
S_{12}	Small-signal reverse isolation (@ $f_{in} < 12\text{ GHz}$)		30		dB
ϕ_N	SSB phase noise (@ $P_{in} = 0\text{ dBm}$, 100 kHz offset from a $f_{out} = 1.2\text{ GHz}$ carrier)		-153		dBc/Hz
Jitter	Input signal time variation @ zero-crossing ($f_{in} = 10\text{ GHz}$, $P_{in} = -10\text{ dBm}$)		1		ps
T_r or T_f	Output transition time (10% to 90% rise/fall time)		70		ps
P_{out}^3	@ $f_{out} < 1\text{ GHz}$	4	6		dBm
	@ $f_{out} = 2.5\text{ GHz}$	3.5	5.5		dBm
	@ $f_{out} = 3.5\text{ GHz}$	0	2.0		dBm
$ V_{out(p-p)} ^4$	@ $f_{out} < 1\text{ GHz}$		0.99		Volts
	@ $f_{out} = 2.5\text{ GHz}$		0.94		Volts
	@ $f_{out} = 3.5\text{ GHz}$		0.63		Volts
$P_{Spitback}$	f_{out} power level appearing at RF_{in} or \overline{RF}_{in} (@ $f_{in} = 12\text{ GHz}$, unused RF_{out} or \overline{RF}_{out} unterminated)		-40		dBm
	f_{out} power level appearing at RF_{in} or \overline{RF}_{in} (@ $f_{in} = 12\text{ GHz}$, both RF_{out} and \overline{RF}_{out} terminated)		-47		dBm
$P_{feedthru}$	Power level of f_{in} appearing at RF_{out} or \overline{RF}_{out} (@ $f_{in} = 10\text{ GHz}$, $P_{in} = 0\text{ dBm}$, referred to $P_{in}(f_{in})$)		-23		dBc
H_2	Second harmonic distortion output level (@ $f_{out} = 3.0\text{ GHz}$, referred to $P_{out}(f_{out})$)		-25		dBc

1. For sine-wave input signal. Prescaler will operate down to D.C. for square-wave input signal. Minimum divide frequency limited by input slew-rate.
2. Prescaler may exhibit this output signal under bias in the absence of an RF input signal. This condition may be eliminated by use of the Input dc offset technique described on page 4.
3. Fundamental of output square wave's Fourier Series.
4. Square wave amplitude calculated from P_{out} .

Applications

The HMMC-3104 is designed for use in high frequency communications, microwave instrumentation, and EW radar systems where low phase-noise PLL control circuitry or broad-band frequency translation is required.

Operation

The device is designed to operate when driven with either a single-ended or differential sinusoidal input signal over a 200 MHz to 16 GHz bandwidth. Below 200 MHz the prescaler input is “slew-rate” limited, requiring fast rising and falling edge speeds to properly divide. The device will operate at frequencies down to dc when driven with a square-wave.

Due to the presence of an off-chip RF-bypass capacitor inside the package (connected to the VCC contact on the device), and the unique design of the device itself, the component may be biased from either a single positive or single negative supply bias. The backside of the package is not dc connected to any dc bias point on the device.

For positive supply operation, VCC pins are nominally biased at any voltage in the +4.5 to +6.5 volt range with pin 8 (VEE) grounded. For negative bias operation VCC pins are typically grounded and a negative voltage between -4.5 to -6.5 volts is applied to pin 8 (VEE).

ac-Coupling and dc-Blocking

All RF ports are dc connected on-chip to the VCC contact through on-chip 50 Ω resistors. Under any bias conditions where VCC is not dc grounded the RF ports should be ac coupled via series capacitors mounted on the PC-board at each RF port. Only under bias conditions where VCC is dc grounded (as is typical for negative bias supply operation) may the RF ports be direct coupled to adjacent circuitry or in some cases, such as level shifting to subsequent stages. In the latter case the package heat sink may be “floated” and bias applied as the difference between VCC and VEE.

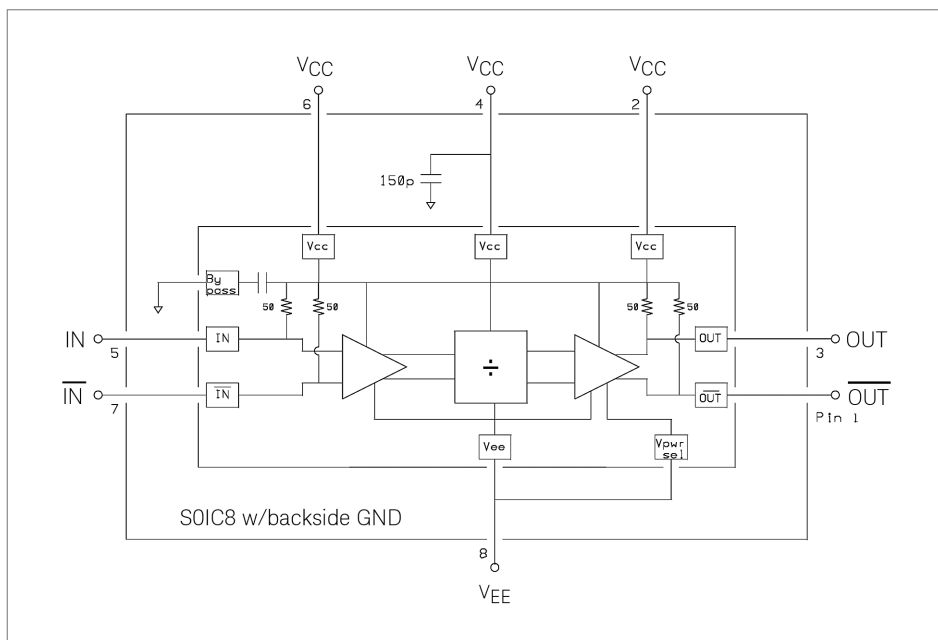

Figure 1. Simplified schematic diagram

Input dc Offset

If an RF signal with sufficient signal to noise ratio is present at the RF input lead, the prescaler will operate and provide a divided output equal the input frequency divided by the divide modulus. Under certain “ideal” conditions where the input is well matched at the right input frequency, the component may “self-oscillate”, especially under small signal input powers or with only noise present at the input. This “self-oscillation” will produce a undesired output signal also known as a false trigger. To prevent false triggers or self-oscillation conditions, apply a 20 to 100 mV dc offset voltage between the RFin and RF_{in} ports. This prevents noise or spurious low level signals from triggering the divider.

Adding a 10 k Ω resistor between the unused RF input to a contact point at the V_{EE} potential will result in an offset of \approx 25 mV between the RF inputs. Note however, that the input sensitivity will be reduced slightly due to the presence of this offset.

Assembly Notes

Independent of the bias applied to the package, the backside of the package should always be connected to both a good RF ground plane and a good thermal heat sinking region on the PC board to optimize performance. For single-ended output operation the unused RF output lead should be terminated into 50 Ω to a contact point at the VCC potential or to RF ground through a dc blocking capacitor.

A minimum RF and thermal PC board contact area equal to or greater than 2.67 \times 1.65 mm (0.105” \times 0.065”) with eight 0.020” diameter plated-wall thermal vias is recommended.

MMIC ESD precautions, handling considerations, die attach and bonding methods are critical factors in successful GaAs MMIC performance and reliability.

Keysight application note, literature number 5991-3484EN, *GaAs MMIC ESD, Die Attach and Bonding Guidelines* provides basic information on these subjects.

Moisture Sensitivity Classification: Class 5A, per JESD22-A112-A.

Additional References

Keysight Technologies Technical Overview, literature number 5991-3578EN, *HBT Prescaler Evaluation Board*.

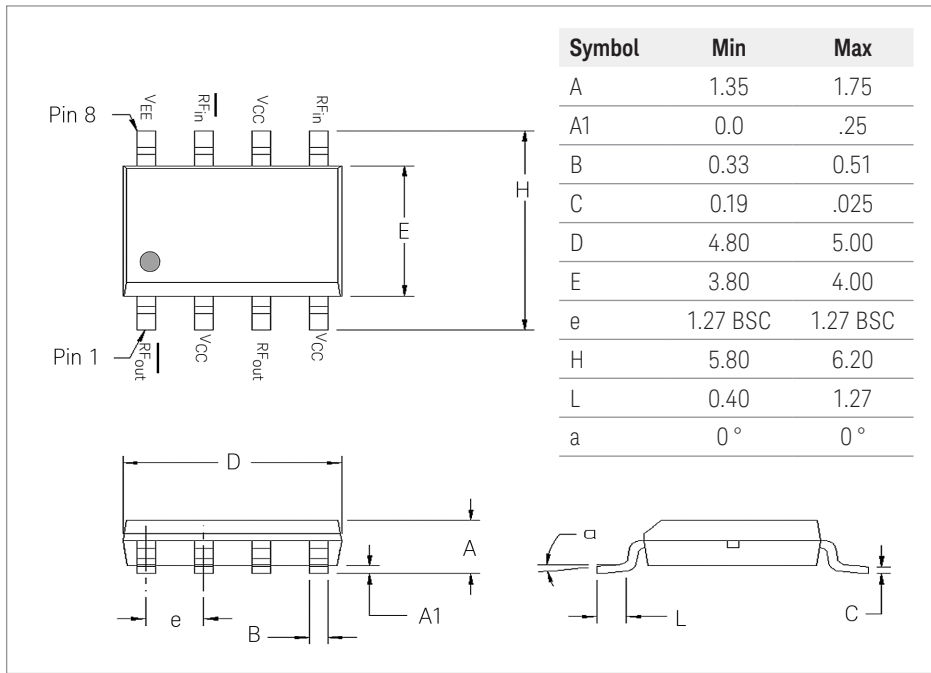

Notes

- All dimensions in millimeters.
- Refer to JEDEC Outline MS-012 for additional tolerances.
- Exposed heat slug area on package bottom = 2.67 × 1.65.
- Exposed heat sink on package bottom must be soldered to PCB rf ground plane.

Figure 2. Package and dimensions

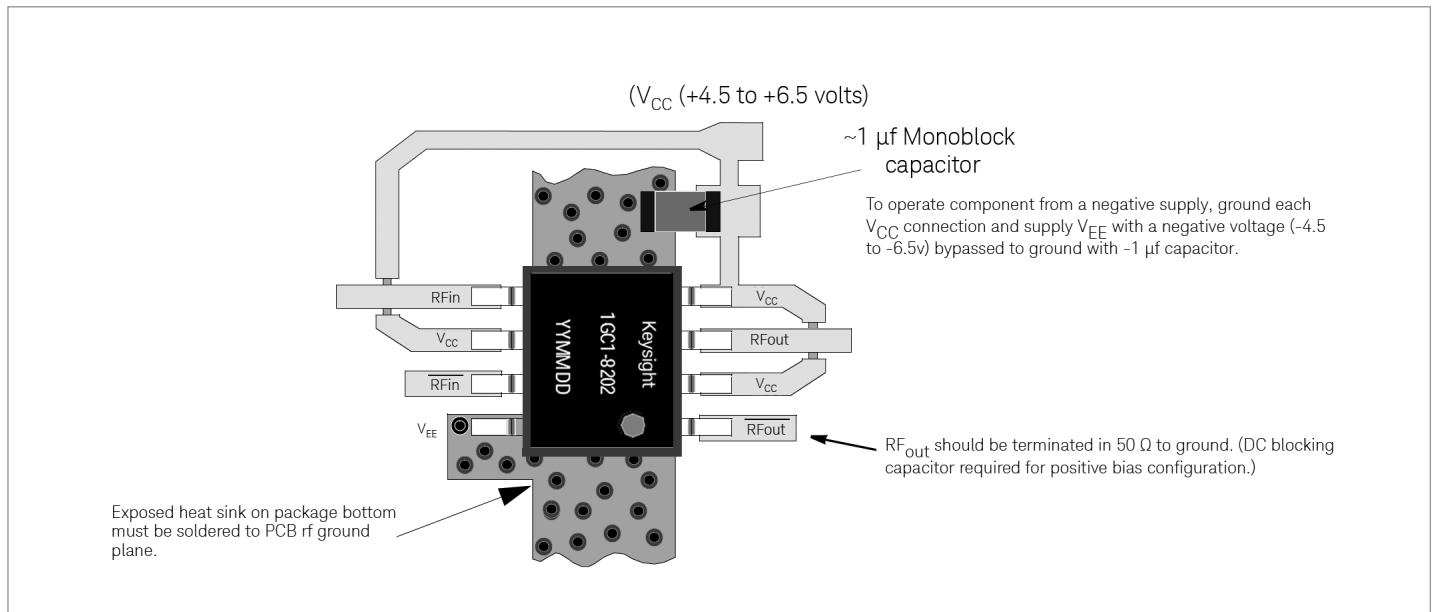

Figure 3. Assembly diagram (Single-supply, positive-bias configuration shown)

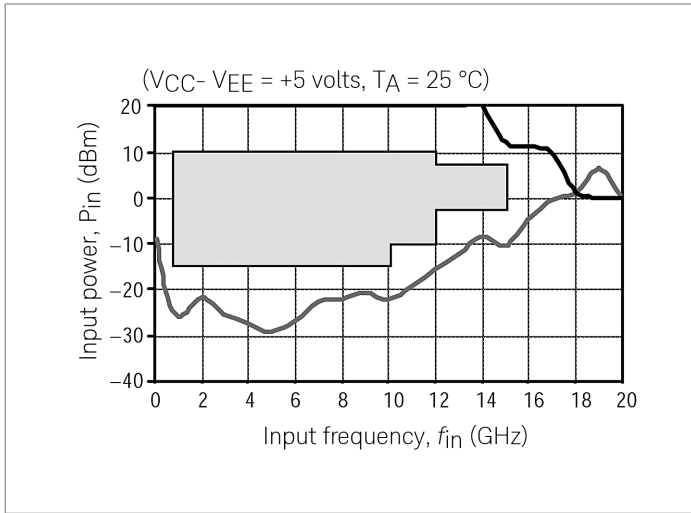

Figure 4. Typical input sensitivity window

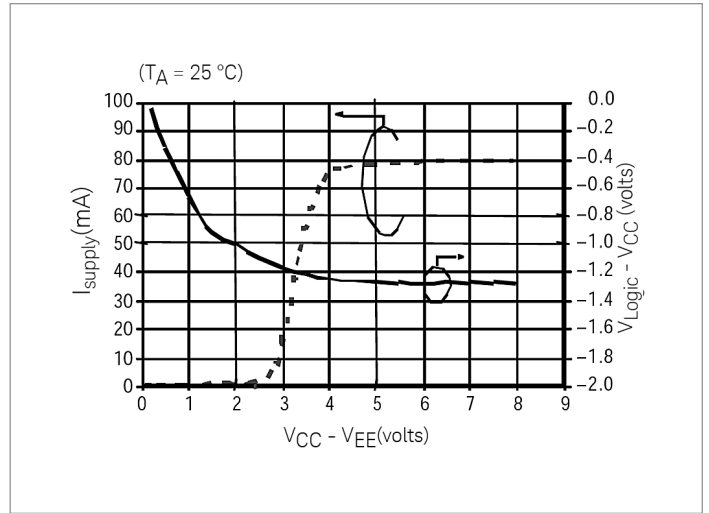

Figure 5. Typical supply current & V_{Logic} vs. supply voltage

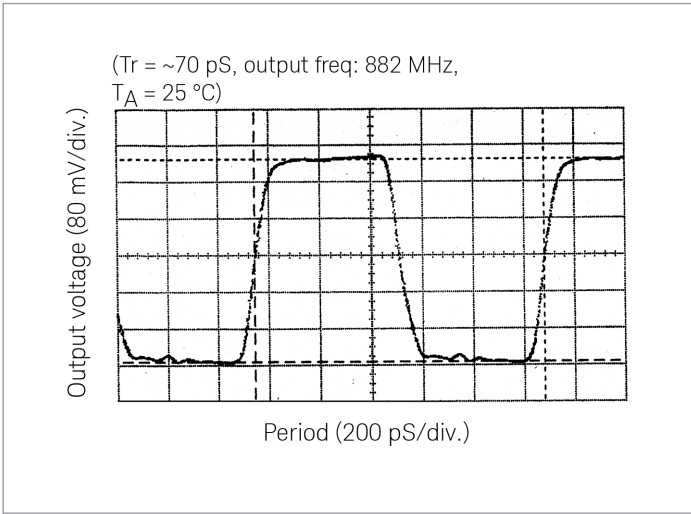

Figure 6. Typical output voltage waveform

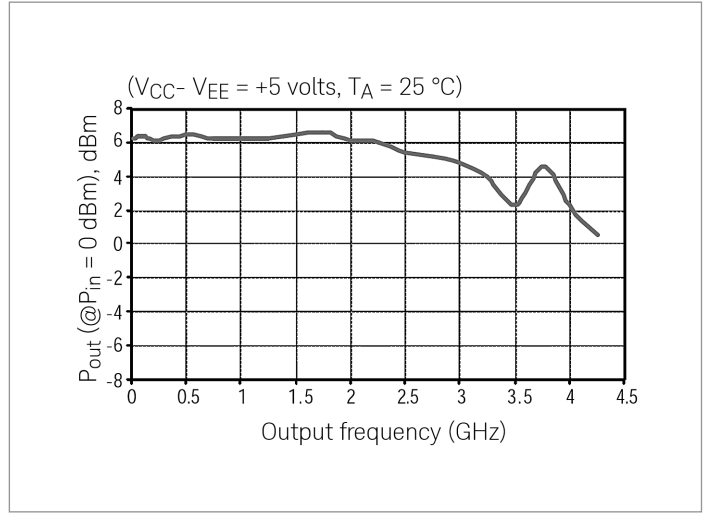

Figure 7. Typical output power vs. output frequency, f_{out} (GHz)

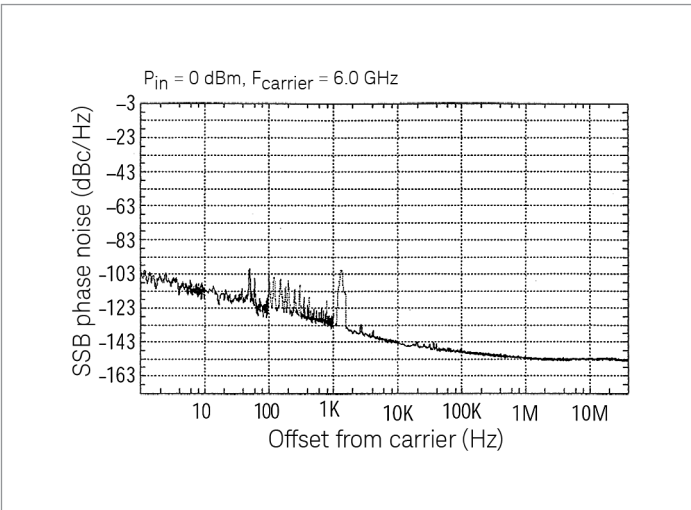

Figure 8. Typical phase noise performance

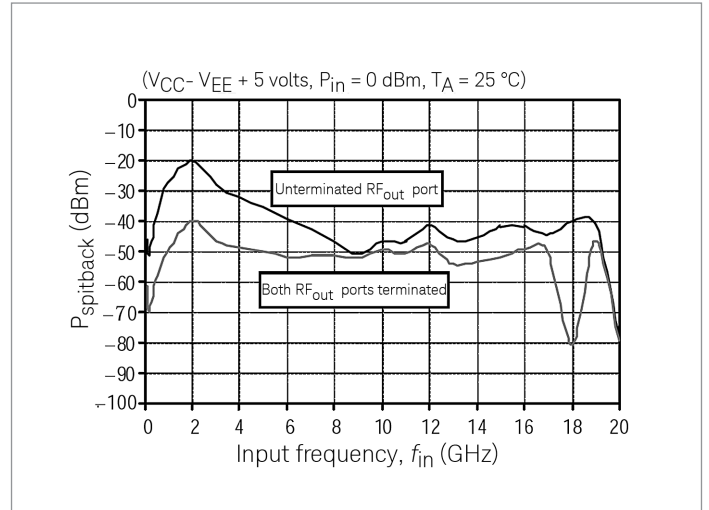
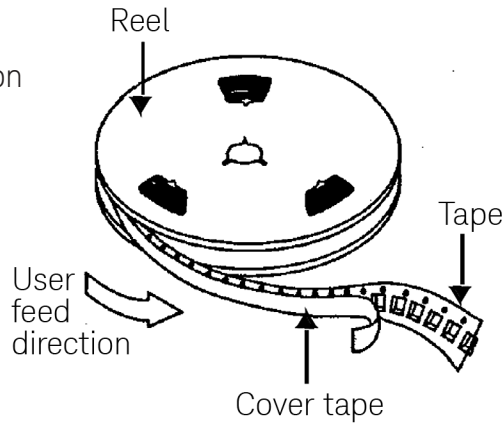

Figure 9. Typical HMMC-3104 "Spitback" power $P(f_{out})$ appearing at RF input port

Device orientation



Notes

1. 10 sprocket hole pitch cumulative tolerance: 0.2 mm.
2. Camber not to exceed 1 mm in 100 mm.
3. Material: Black Conductive Advantek Polystyrene.
4. Ao and Bo measured on a plane 0.3 mm above the bottom of the pocket.
5. Ko measured from a plane on the inside bottom of the pocket to the top surface of the carrier.
6. Pocket position relative to sprocket hole measured as true position of pocket, not pocket hole.

Tape dimensions and product orientation

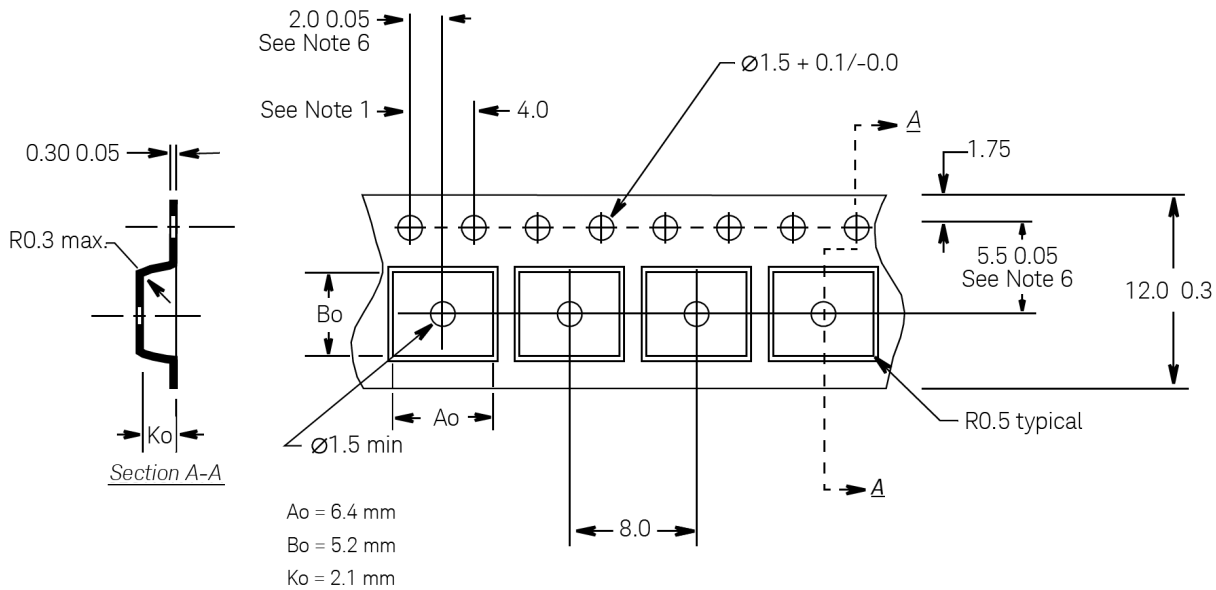

This data sheet contains a variety of typical and guaranteed performance data. The information supplied should not be interpreted as a complete list of circuit specifications. Customers considering the use of this, or other Keysight Technologies GaAs ICs, for their design should obtain the current production specifications from Keysight. In this data sheet the term typical refers to the 50th percentile performance. For additional information contact Keysight at MMIC_Helpline@keysight.com.

Evolving Since 1939

Our unique combination of hardware, software, services, and people can help you reach your next breakthrough. We are unlocking the future of technology.

From Hewlett-Packard to Agilent to Keysight.

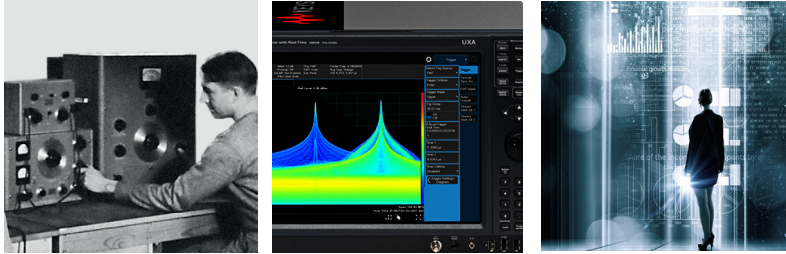

For more information on Keysight Technologies' products, applications or services, please contact your local Keysight office. The complete list is available at: www.keysight.com/find/contactus

Americas

Canada	(877) 894 4414
Brazil	55 11 3351 7010
Mexico	001 800 254 2440
United States	(800) 829 4444

Asia Pacific

Australia	1 800 629 485
China	800 810 0189
Hong Kong	800 938 693
India	1 800 11 2626
Japan	0120 (421) 345
Korea	080 769 0800
Malaysia	1 800 888 848
Singapore	1 800 375 8100
Taiwan	0800 047 866
Other AP Countries	(65) 6375 8100

Europe & Middle East

Austria	0800 001122
Belgium	0800 58580
Finland	0800 523252
France	0805 980333
Germany	0800 6270999
Ireland	1800 832700
Israel	1 809 343051
Italy	800 599100
Luxembourg	+32 800 58580
Netherlands	0800 0233200
Russia	8800 5009286
Spain	800 000154
Sweden	0200 882255
Switzerland	0800 805353
	Opt. 1 (DE)
	Opt. 2 (FR)
	Opt. 3 (IT)
United Kingdom	0800 0260637

For other unlisted countries: www.keysight.com/find/contactus (BP-9-7-17)

DEKRA Certified
ISO 9001 Quality Management System

www.keysight.com/go/quality
Keysight Technologies, Inc.
DEKRA Certified ISO 9001:2015
Quality Management System

myKeysight

myKeysight

www.keysight.com/find/mykeysight

A personalized view into the information most relevant to you.

www.keysight.com/find/emt_product_registration

Register your products to get up-to-date product information and find warranty information.

KEYSIGHT SERVICES

Accelerate Technology Adoption.
Lower costs.

Keysight Services

www.keysight.com/find/service

Keysight Services can help from acquisition to renewal across your instrument's lifecycle. Our comprehensive service offerings—one-stop calibration, repair, asset management, technology refresh, consulting, training and more—helps you improve product quality and lower costs.



Keysight Assurance Plans

www.keysight.com/find/AssurancePlans

Up to ten years of protection and no budgetary surprises to ensure your instruments are operating to specification, so you can rely on accurate measurements.

Keysight Channel Partners

www.keysight.com/find/channelpartners

Get the best of both worlds: Keysight's measurement expertise and product breadth, combined with channel partner convenience.

www.keysight.com/find/emc



Unlocking Measurement Insights

This information is subject to change without notice.
© Keysight Technologies, 2017
Published in USA, December 1, 2017
5989-7350EN
www.keysight.com