

Installation Note

A2 Controller Assembly Replacement Kit



HP Part No. 08564-90029 Supersedes 5962-5042
Printed in USA November 1997

MARKUP COPY

© Copyright 1993, 1994, 1997 Hewlett-Packard Company. All Rights Reserved. Reproduction, adaptation, or translation without prior written permission is prohibited, except as allowed under the copyright laws.
1400 Fountaingrove Parkway, Santa Rosa, CA 95403-1799, USA

A2 Controller Assembly Replacement Kit

INSTRUMENTS AFFECTED:	HP 8560E spectrum analyzers HP 8561E spectrum analyzers HP 8563E spectrum analyzers
SERIAL NUMBERS:	HP 8560E – 0000A00000/3305A00438 HP 8561E – 0000A00000/3305A00332 HP 8563E – 0000A00000/3305A00999
TO BE PERFORMED BY:	Customer or HP-Qualified Personnel

What You'll Find in This Installation Note

This installation note describes how to replace an older A2 controller assembly, HP part number 08563-60017, with a newer A2 controller. The new A2 controllers use a 16 MHz CPU.

The firmware that comes with the new A2 controller provides more frequency response correction points, supports Option 008 Signal Identification (SIG ID), and adds enhancements for adjacent channel power (ACP), power measurements, and amplitude correction (AMPCOR).

After the new A2 Controller is installed, the analyzer's serial number and identification (ID) string must be downloaded into the analyzer's EEROM. Option 008 will be added to the ID string. The analyzer's frequency response will also be readjusted since the new correction points are in different memory locations in the spectrum analyzer's larger EEROM.

Note The new A2 Controller phase-locks its CPU clock to the 10 MHz reference from the A15 RF Assembly. With older A15 RF Assemblies, if the analyzer is placed into external reference mode without an external reference supplied, no 10 MHz reference will be supplied to the A2 Controller. The display will appear distorted if no 10 MHz reference is supplied to A2. This is normal.

Safety Considerations

Warning Before you disassemble the instrument, turn the power switch OFF and unplug the spectrum analyzer. Failure to unplug the spectrum analyzer can result in personal injury.

Caution Electrostatic discharge (ESD) can damage or destroy electronic components. All work on electronic assemblies should be performed at a static-safe work station. Refer to the appropriate spectrum analyzer calibration guide for information about a static-safe work station and ordering static-safe accessories.

Items Shipped with Installation Kit

Table 1-1 lists the parts shipped with the A2 Controller Assembly Replacement Kit, HP part number 08563-60058.

Table 1-1. A2 Controller Assembly Replacement Kit Parts List

Quantity	Description	HP Part Number
1	Installation note	08564-90029
1	A2 controller assembly	08564-60025
1	A2/firmware upgrade software	5010-7713

Required Tools

Table 1-2 lists the tools required to install the new A2 controller assembly.

Table 1-2. Required Tools

Description	HP Part Number
4-mm hex (Allen) wrench	8710-1164
T-10 TORX screwdriver	8710-1623
#1 Pozidrive screwdriver	8710-0899

Required Equipment

Table 1-3 lists the equipment required to run the A2/firmware upgrade software and perform the frequency response adjustment and the 16 MHz PLL adjustment. An HP 85629B test and adjustment module (TAM) is recommended for performing the frequency response adjustment.

Table 1-3. Required Test Equipment

Test Equipment	Recommended HP Model Number
Synthesized Sweeper	HP 8340A/B
Measuring Receiver	HP 8902A
Microwave Frequency Counter	HP 5343A
Power Splitter (HP 8563E only)	HP 11667B
Power Splitter (HP 8560E or HP 8561E)	HP 11667A
Power Sensor	HP 8482A
Power Sensor (HP 8563E only)	HP 8485A
Power Sensor (HP 8560E or HP 8561E)	HP 8481A
10:1 Probe	HP 10432A
Computer (with HP Basic 3.0 or later)	HP 9000, Model 216, 236, or 310
Adapters	
Type-N(m) to APC 3.5(m)	1250-1743
Type-N(f) to APC 3.5(m)	1250-1750
APC 3.5(f) to APC 3.5(f)	5061-5311
Cables	
BNC, 122 cm (48 in)	HP 10503A
APC 3.5, 91 cm (36 in)	8120-4921
HP-IB, 2 m	HP 10833B

Installation Procedure

Record the EEROM Data

1. Remove the spectrum analyzer cover assembly as described in procedure 1 of chapter 3.
2. Move the WR PROT/WR ENA jumper on the A2 controller assembly to the WR ENA position.
3. Connect a power cord to the spectrum analyzer and set the LINE switch ON. Wait for the power-on adjustments to complete.
4. Press **CAL**, **MORE 1 OF 2**, **SERVICE CAL DATA**.
5. If the spectrum analyzer is not an HP 8560E with Option 002, press **3RD IF AMP**, **EXT MXR REF CAL**. Record the displayed EXT MXR REF CAL below.

EXT MXR REF CAL _____ Vdc

6. On the spectrum analyzer, press **PRESET**, and set the controls as follows:

Center frequency	1.45 GHz
Span	0 Hz
7. Press **CAL**, **MORE 1 OF 2**, **SERVICE CAL DATA**, **LO LEVELS**, **LO GATE LEVEL**. Record the LO GATE DAC value in Table 2-1.
8. Press **INT LO LEVEL**. The message DRIVE FOR BAND# 0 should be displayed. Record the LO DRIVE DAC value for Band 0 in Table 2-1.
9. Skip to step 14 if the spectrum analyzer is an HP 8560E.
10. Press **↑**. The message DRIVE FOR BAND# 1 should be displayed. Record the LO DRIVE DAC value for Band 1 in Table 2-1.
11. Skip to step 14 if the spectrum analyzer is an HP 8561E.
12. Press **↑**. The message DRIVE FOR BAND# 2 should be displayed. Record the LO DRIVE DAC value for Band 2 in Table 2-1.
13. Press **↑**. The message DRIVE FOR BAND# 3 should be displayed. Record the LO DRIVE DAC value for Band 3 in Table 2-1.
14. Press **EXT LO LEVEL**. Record the LO DRIVE DAC value for External mixing in Table 2-1.

Table 2-1. LO Levels DAC Values

Local Oscillator DAC	DAC Value
LO GATE DAC	_____
LO DRIVE DAC, Band 0	_____
LO DRIVE DAC, Band 1	_____ *
LO DRIVE DAC, Band 2	_____ †
LO DRIVE DAC, Band 3	_____ †
LO DRIVE DAC, External	_____
* Applies only to HP 8561E and HP 8563E.	
† Applies only to HP 8563E.	

15. If the spectrum analyzer is an HP 8561E, press **BAND 1 MXR BIAS**. Record the INT MXR BIAS DAC value below.

INT MXR BIAS DAC _____

16. Press **PREV MENU**.

17. If spectrum analyzer is an HP 8560E, skip to step 27.

18. On the spectrum analyzer, press **PRESET**, and set the controls as follows:

Center frequency 4.0 GHz
 Span 0 Hz

19. Press **CAL**, **MORE 1 OF 2**, **SERVICE CAL DATA**, **PRESEL ADJ**, **PRESEL OFFSET**. Record the PRESEL OFFSET DAC value for Band 1 in Table 2-2.

20. If spectrum analyzer is an HP 8561E, skip to step 23.

21. Press **↑**. Record the PRESEL OFFSET DAC value for Band 2 in Table 2-2.

22. Press **↑**. Record the PRESEL OFFSET DAC value for Band 3 in Table 2-2.

23. Press **PRESEL SLOPE**. If necessary, press **↓** until the message SLOPE FOR BAND # 1 is displayed. Record the PRESEL SLOPE DAC value for Band 1 in Table 2-2.

24. If spectrum analyzer is an HP 8561E, skip to step 27.

25. Press **↑**. Record the PRESEL SLOPE DAC value for Band 2 in Table 2-2.

26. Press **↑**. Record the PRESEL SLOPE DAC value for Band 3 in Table 2-2.

Table 2-2. Preselector DAC Values

Band Number	PRESEL OFFSET DAC	PRESEL SLOPE DAC
Band 1	_____	_____
Band 2 *	_____	_____
Band 3 *	_____	_____
* Applies only to HP 8563E.		

27. Place WR PROT/WR ENA jumper on the A2 controller assembly in the WR PROT position. Set the spectrum analyzer LINE switch off.

Install New A2 Controller Assembly

1. Replace the existing A2 controller assembly with the A2 included in the kit. The replacement is described in chapter 3.
2. Connect W22, the black coax cable, to A2J8, the SMB connector nearest the front of the spectrum analyzer.
3. Perform the 16 MHz CPU PLL Adjustment as described in chapter 3.

Download the Serial Number and ID String

1. Move the WR PROT/WR ENA jumper on the A2 controller assembly to the WR ENA position.
2. Set up the computer as described in the operation verification chapter of the calibration guide or installation and verification manual. Connect an HP-IB cable between the computer and the spectrum analyzer.
3. Connect a power cord to the spectrum analyzer and set the LINE switch ON. Wait for the power-on adjustments to complete. Ignore any error messages.
4. On the spectrum analyzer, press **CONFIG**, **ANALYZER ADDRESS**. If the current address is not 18, press 18, **ENTER** (the **Hz** key), and **STORE HPIB ADR**.
5. Load and run the FW_UPGRADE program on the A2 firmware upgrade software disc supplied with the kit. This program is used to download the spectrum analyzer's serial number and ID string into its EEROM. This information must be present for the spectrum analyzer to function correctly.
 - a. The software will prompt you to enter the serial number prefix and the serial number suffix. For example, if the complete serial number is 3221A00129, enter 3221 for the prefix (the program will automatically append the A) and enter 00129 for the suffix.
 - b. Next you will be prompted to enter the spectrum analyzer model number. A list of valid model numbers will be displayed. Enter the model number exactly as it appears in the list. All alphabetic characters must be uppercase.
 - c. You will then be prompted to indicate if there are any options installed. Since spectrum analyzers with a serial prefix of 3305A and below have the signal identification feature as

- standard, answer 'Y' (yes) and enter Option 008. If there are any other options installed, add the appropriate option number. Enter a Q (quit) if there are no more options to add to the ID string.
- d. This program can be used a maximum of three times. If a successful download of the serial number and ID string cannot be obtained in three attempts, it will be necessary to send the spectrum analyzer to an HP customer service center to complete the installation.
6. After successfully downloading the new ID string, turn the spectrum analyzer power off and on. Some error messages will still appear; these will be cleared later.
 7. Press **CONFIG**, **DATECODE & OPTIONS**. Under Options: should appear the spectrum analyzer's model number and 008, along with any other installed options.

Reload the EEROM Data

1. Press **DISPLAY**, **INTENSTY**, 120, **ENTER** (the **Hz** key), and **STORE INTENSTY**.
2. Press **MORE 1 OF 2**, **FOCUS**, 128, **ENTER**, **STORE FOCUS**.
3. Press **SAVE**, **PWR ON STATE**.
4. Connect a BNC cable from the CAL OUTPUT to INPUT 50Ω.
5. Press **CAL**, **MORE 1 OF 2**, **SERVICE CAL DATA**, **3RD IF AMP**. Press **CAL 3RD AMP GAIN** and wait until the message ADJUSTMENT DONE is displayed.
6. If the spectrum analyzer is not an HP 8560E with Option 002, press **EXT MXR REF CAL**. Enter the value recorded in step 5 of the "Record the EEROM Data" procedure.
7. Press **PREV MENU**, **STORE DATA**, **YES**.
8. On the spectrum analyzer, press **PRESET**, and set the controls as follows:

Center frequency	1.45 GHz
Span	0 Hz
9. Press **CAL**, **MORE 1 OF 2**, **SERVICE CAL DATA**, **LO LEVELS**, **LO GATE LEVEL**. Enter the LO GATE DAC value from Table 2-1.
10. Press **INT LO LEVEL**. The message DRIVE FOR BAND# 0 should be displayed. Enter the LO DRIVE DAC value for Band 0 from Table 2-1.
11. If the spectrum analyzer is an HP 8560E, skip to step 16.
12. Press **↕**. The message DRIVE FOR BAND# 1 should be displayed. Enter the LO DRIVE DAC value for Band 1 from Table 2-1.
13. If the spectrum analyzer is an HP 8561E, skip to step 16.
14. Press **↕**. The message DRIVE FOR BAND# 2 should be displayed. Enter the LO DRIVE DAC value for Band 2 from Table 2-1.
15. Press **↕**. The message DRIVE FOR BAND# 3 should be displayed. Enter the LO DRIVE DAC value for Band 3 from Table 2-1.
16. Press **EXT LO LEVEL**. Enter the LO DRIVE DAC value for External mixing from Table 2-1.

17. If spectrum analyzer is an HP 8561E, press **BAND 1 MXR BIAS**. Enter the INT MXR BIAS DAC value recorded in step 15 of the "Record the EEROM Data" procedure.
18. Press **PREV MENU**, **STORE DATA**, **YES**.
19. If the spectrum analyzer is an HP 8560E, skip to step 29.
20. On the spectrum analyzer, press **PRESET**, and set the controls as follows:

Center frequency	4.0 GHz
Span	0 Hz
21. Press **CAL**, **MORE 1 OF 2**, **SERVICE CAL DATA**, **PRESEL ADJ**, **PRESEL OFFSET**. Enter the PRESEL OFFSET DAC value for Band 1 from Table 2-2.
22. If the spectrum analyzer is an HP 8561E, skip to step 25.
23. Press **↑**. Enter the PRESEL OFFSET DAC value for Band 2 from Table 2-2.
24. Press **↑**. Enter the PRESEL OFFSET DAC value for Band 3 from Table 2-2.
25. Press **PRESEL SLOPE**. If necessary, press **↓** until the message SLOPE FOR BAND # 1 is displayed. Enter the PRESEL SLOPE DAC value for Band 1 from Table 2-2.
26. If the spectrum analyzer is an HP 8561E, skip to step 29.
27. Press **↑**. Enter the PRESEL SLOPE DAC value for Band 2 from Table 2-2.
28. Press **↑**. Enter the PRESEL SLOPE DAC value for Band 3 from Table 2-2.
29. Press **PREV MENU**, **STORE DATA**, **YES**.
30. Turn the spectrum analyzer power off and on again. Wait for the power-on adjustments to complete. A few error messages will still appear; these will be cleared later.

Perform the Frequency Response Adjustment

1. If an HP 85629B test and adjustment module (TAM) is available, perform the Low Band Flatness and High Band Flatness and YTF adjustments in the TAM's Adjust menu.
 2. If a TAM is not available, perform the appropriate frequency response adjustment procedure in chapter 3:

HP 8560E	Procedure 4
HP 8561E	Procedure 5
HP 8563E	Procedure 6
 3. If the spectrum analyzer is an HP 8561E or HP 8563E, press **SAVE**, **SAVE PRESEL PK**.
 4. Move the WR PROT/WR ENA jumper on A2 to the WR PROT position.
 5. Fold up the A2 and A3 board assemblies as described in procedure 2 in chapter 3.
Install the spectrum analyzer cover as described in procedure 1 in chapter 3.
- The retrofit is complete. Running the operation verification software is recommended.

Replacement and Adjustment Procedures

Procedure 1. Spectrum Analyzer Cover

Removal/Replacement

1. Disconnect the line-power cord, remove any adapters from the front-panel connectors, and place the analyzer on its front panel.
2. If an HP 85620A mass memory module is mounted on the rear panel, remove it. Loosen (but do not remove) the four rear-bumper screws, using a 4-mm hex wrench. Pull the cover assembly off towards the rear of the instrument.

Caution When replacing the spectrum analyzer's cover, use caution to avoid damaging any cables.

3. When installing the cover assembly, be sure to locate the cover's air vent holes on the bottom side of the spectrum analyzer. Attach with the four screws loosened in step 2, and tighten the four screws gradually to ensure that the cover is seated in the front-frame gasket groove.
4. Torque each screw to 40 to 50 inch-pounds to ensure proper EMI gasket compression.

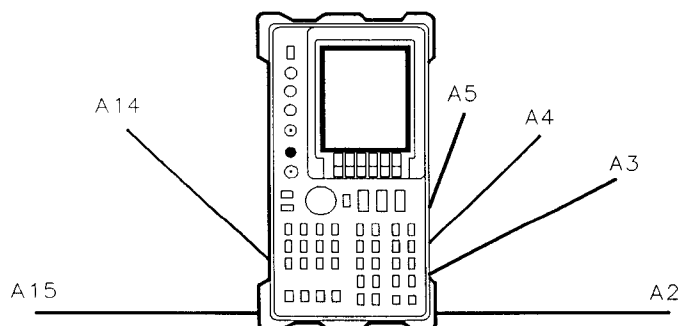

SK 122

Figure 3-1. Hinged Assemblies

Procedure 2. A2, A3, A4, and A5 Assemblies

Removal

1. Remove the spectrum analyzer's cover.
2. Place the spectrum analyzer on its right side frame.
3. Remove the eight screws holding the A2, A3, A4, and A5 assemblies to the top of the analyzer. These screws are labeled (2), (3), and (4) in Figure 3-2. They are also labeled on the back of the A2 board assembly.
4. Remove ribbon cable W4 from A2J6. See Figure 3-2.

Caution Do not fold the board assemblies out of the spectrum analyzer one at a time. Always fold the A2 and A3 assemblies as a unit and the A4 and A5 assemblies as a unit. Folding out one assembly at a time binds the hinges attaching the assemblies and may damage an assembly and hinge.

5. The board assemblies are attached to the spectrum analyzer's right side frame with two hinges. Fold both the A2 and A3 assemblies out of the analyzer as a unit.
6. Fold both the A4 and A5 assemblies out of the spectrum analyzer as a unit.
7. Remove the cables from the assembly being removed, as illustrated in Figure 3-3.
8. Remove the two screws that attach the assembly being removed to its two mounting hinges.

Caution Do not torque shield torx screws to more than 5 inch-pounds. Applying excessive torque will cause the screws to stretch.

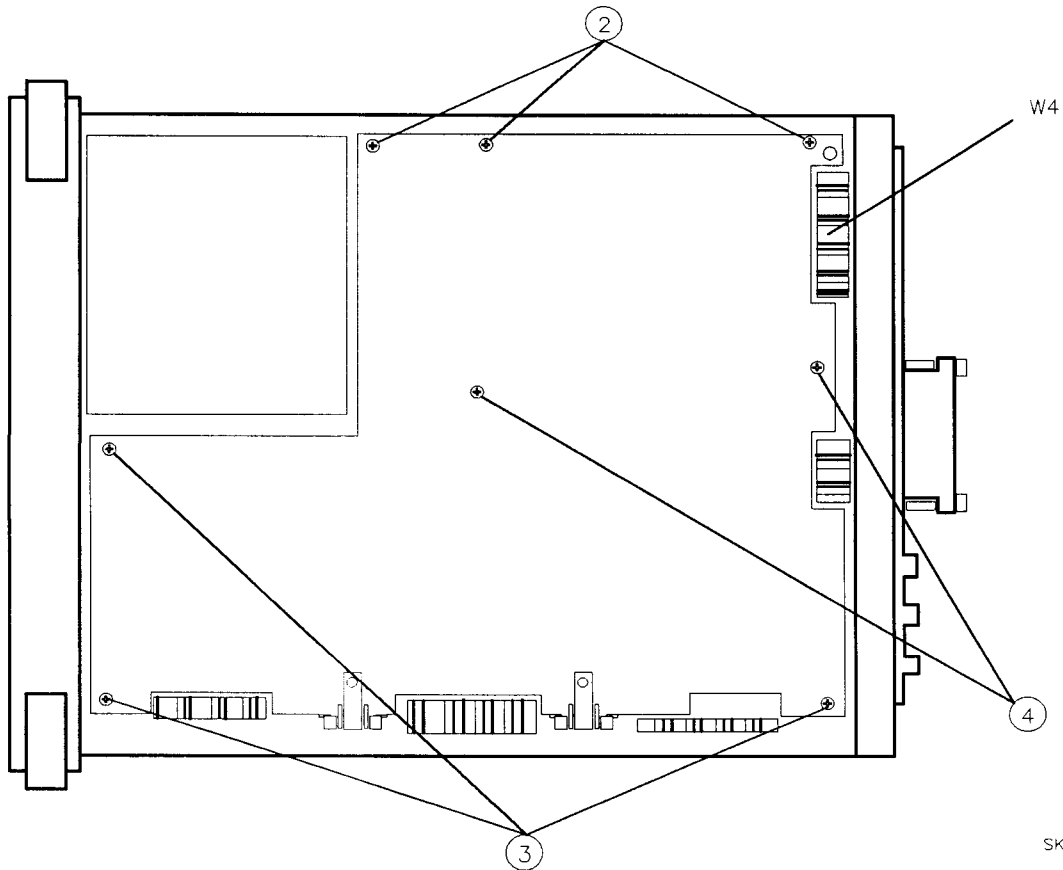

SK129

Figure 3-2. A2, A3, A4, and A5 Assembly Removal

Replacement

1. Place the spectrum analyzer top-side-up on the work bench.
2. Attach the assembly being installed to the two chassis hinges with two panhead screws.
3. Leave the assembly in the folded-out position and attach ribbon cables W1 and W2.
4. Attach all coaxial cables to the assembly, as illustrated in Figure 3-3.
5. Locate the cable clip on the inside of the right-side frame. Make sure that the coaxial cables are routed properly on the clip as illustrated in Figure 3-5.
6. Lay the A2, A3, A4, and A5 assemblies flat against each other in the folded-out position. Make sure that no cables become pinched between any two assemblies.

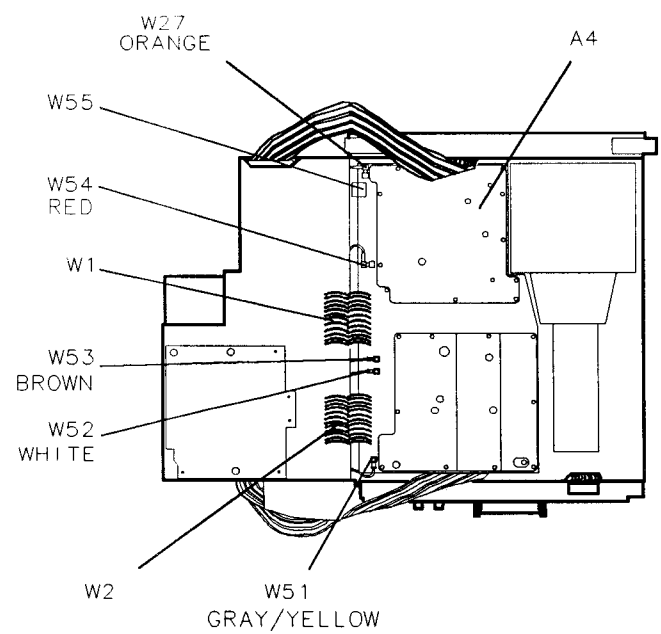
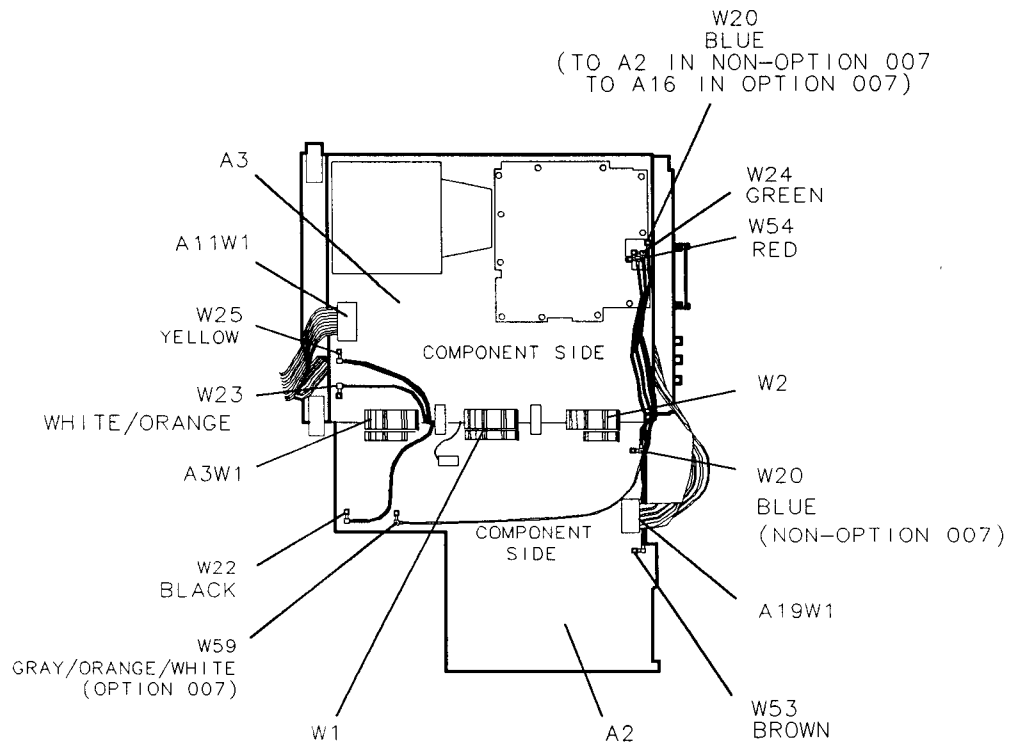

sj12e

Figure 3-3. Assembly Cables (1 of 2)

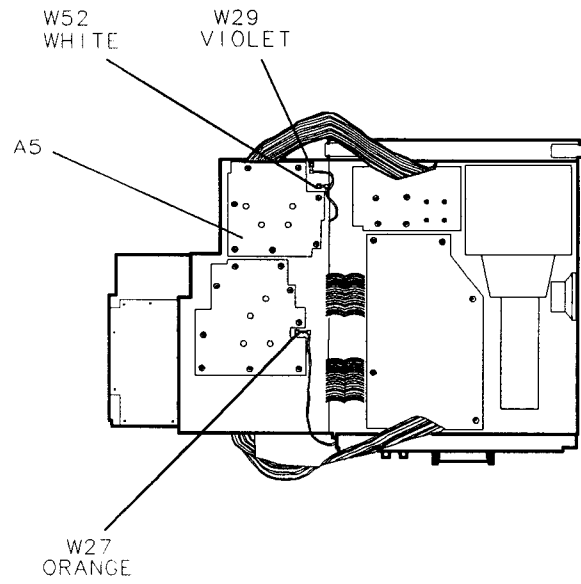

SK131

Figure 3-4. Assembly Cables (2 of 2)

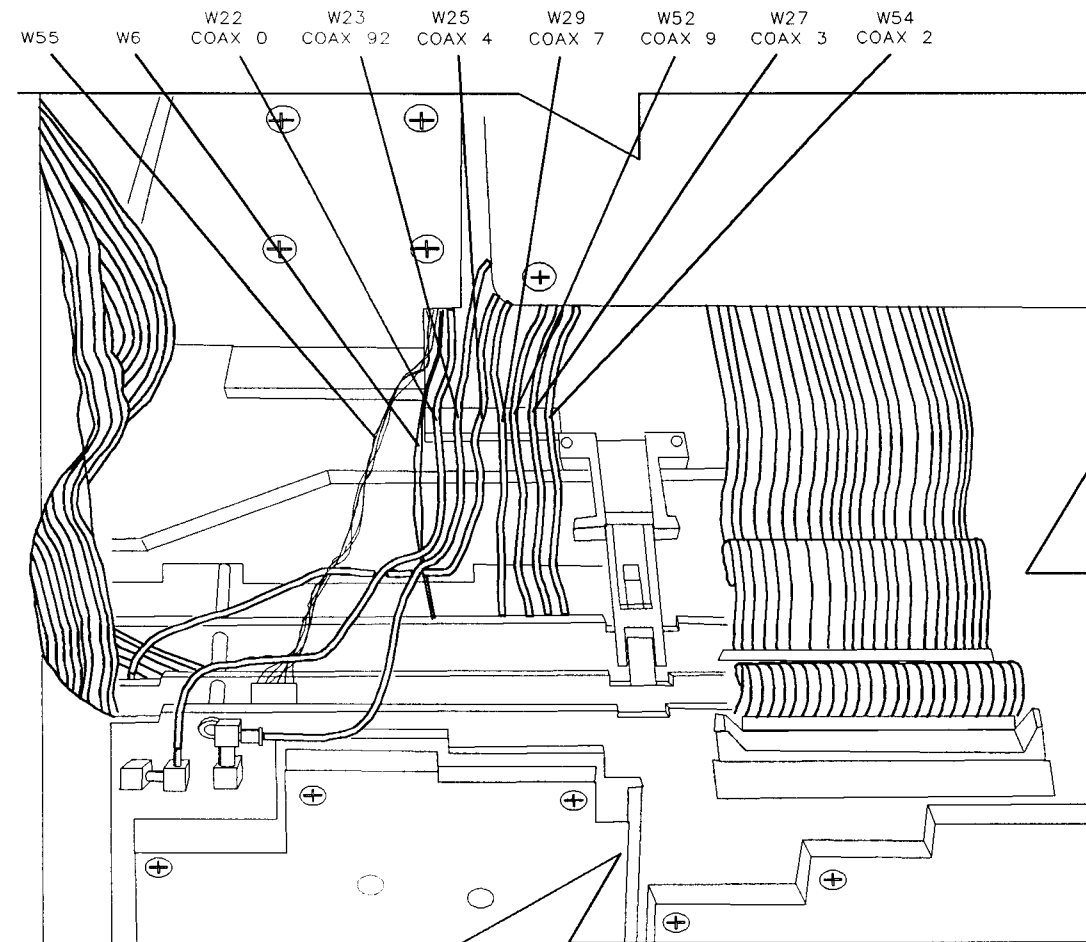

sp142e

Figure 3-5. Coaxial Cable Clip

7. Check to ensure that no cables will become pinched under the hinges when folding up the A4 and A5 assemblies.
8. Fold the A4 and A5 assemblies together as a unit into the analyzer. Use caution to avoid damaging any cable assemblies. The standoffs on the A5 assembly must fit into the cups on the A6 power supply top shield.
9. Fold the A2 and A3 assemblies together as a unit into the spectrum analyzer. Be sure to fold HP-IB cable A19W1 between the A3 and A4 assemblies, using the two sets of hook and loop (Velcro) fasteners.
10. Fold ribbon cable A1A1W1 between A3 and A4 assemblies. Take care to dress the protective tubing as close to A3J602 connector as possible, so that the tubing does not fold with the cable. See Figure 3-6.
11. Attach ribbon cable W4 to A2J6 while folding up the assemblies. See Figure 3-2.
12. Secure the assemblies using the eight screws removed in "Removal" step 3.

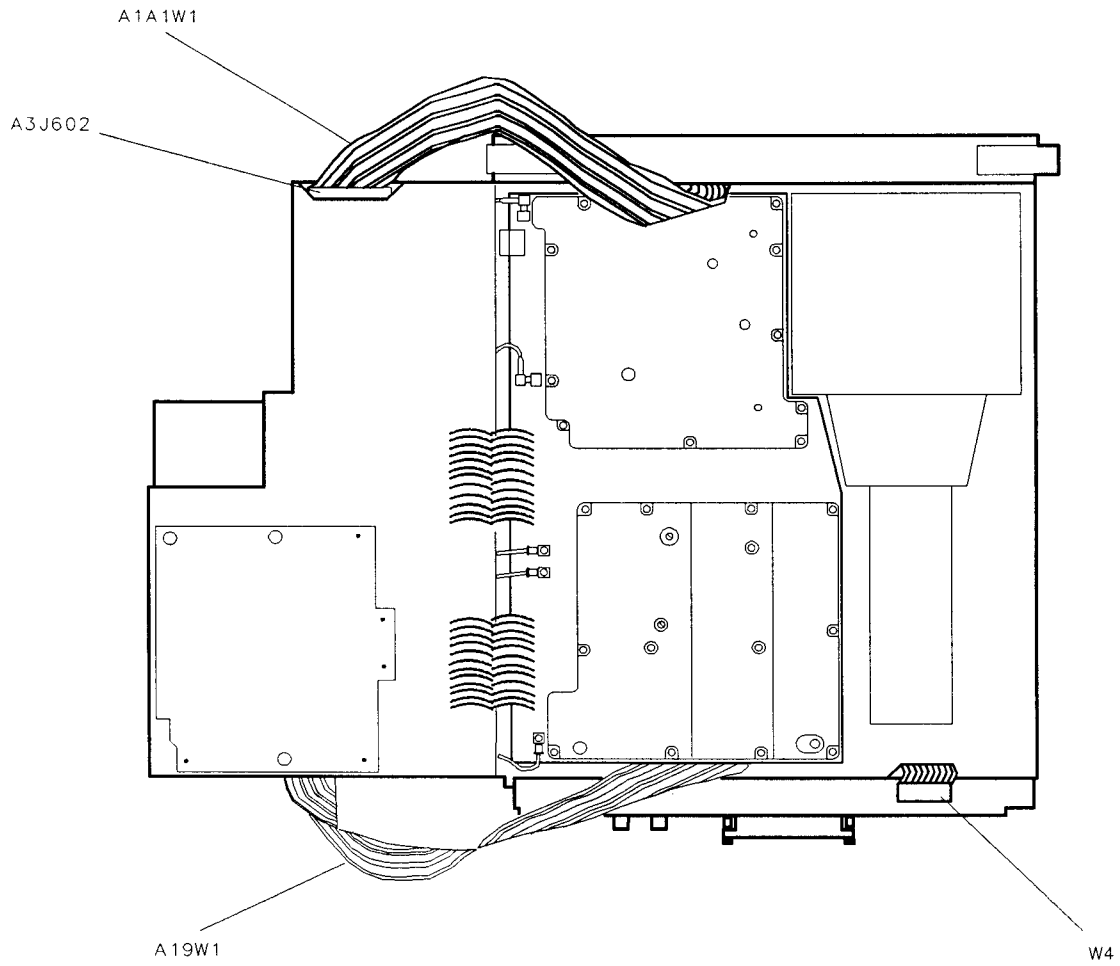

SK133

Figure 3-6. HP-IB and A1A1 W1 Cable Placement

Procedure 3. 16 MHz CPU PLL Adjustment

Note This adjustment applies only to spectrum analyzers with A2 controller assemblies other than 08563-60017.

Assembly Adjusted

A2 Controller Assembly

Related Performance Tests

Sweep Time Accuracy
Gate Delay Accuracy and Gate Length Accuracy
Delayed Sweep Accuracy
Fast Sweep Time Accuracy (Option 007)

Description

In spectrum analyzers with controller assembly part numbers other than 08563-60017, the 16 MHz CPU clock is phase locked to the 10 MHz reference. The output of the 16 MHz PLL's loop integrator is adjusted for a clock frequency of approximately 14.4 MHz with the loop unlocked. This ensures that the CPU will still function and the display annotation will be distorted but readable, even if the 10 MHz reference to A2 is absent.

Note If necessary, perform the display adjustments after performing the following adjustment.

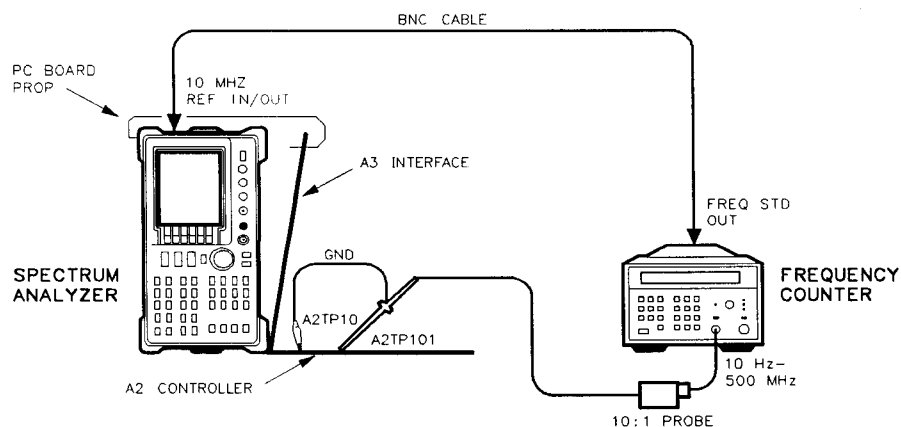

sj140e

Figure 3-7. 16 MHz PLL Adjustment Setup

Equipment

Microwave frequency counter HP 5343A
10:1 Probe HP 10432A

Procedure

1. Set the spectrum analyzer **(LINE)** switch off. Remove the spectrum analyzer's cover and fold out the A2 controller and A3 interface assemblies. Use a pc board prop to hold up the A3 interface assembly, as shown in Figure 3-7.
2. Connect the equipment as shown in Figure 3-7. The 10:1 probe's ground lead connects to A2TP10 and the probe's tip connects to A2TP101.
3. The 16 MHz PLL adjustment location is shown in Figure 3-8.

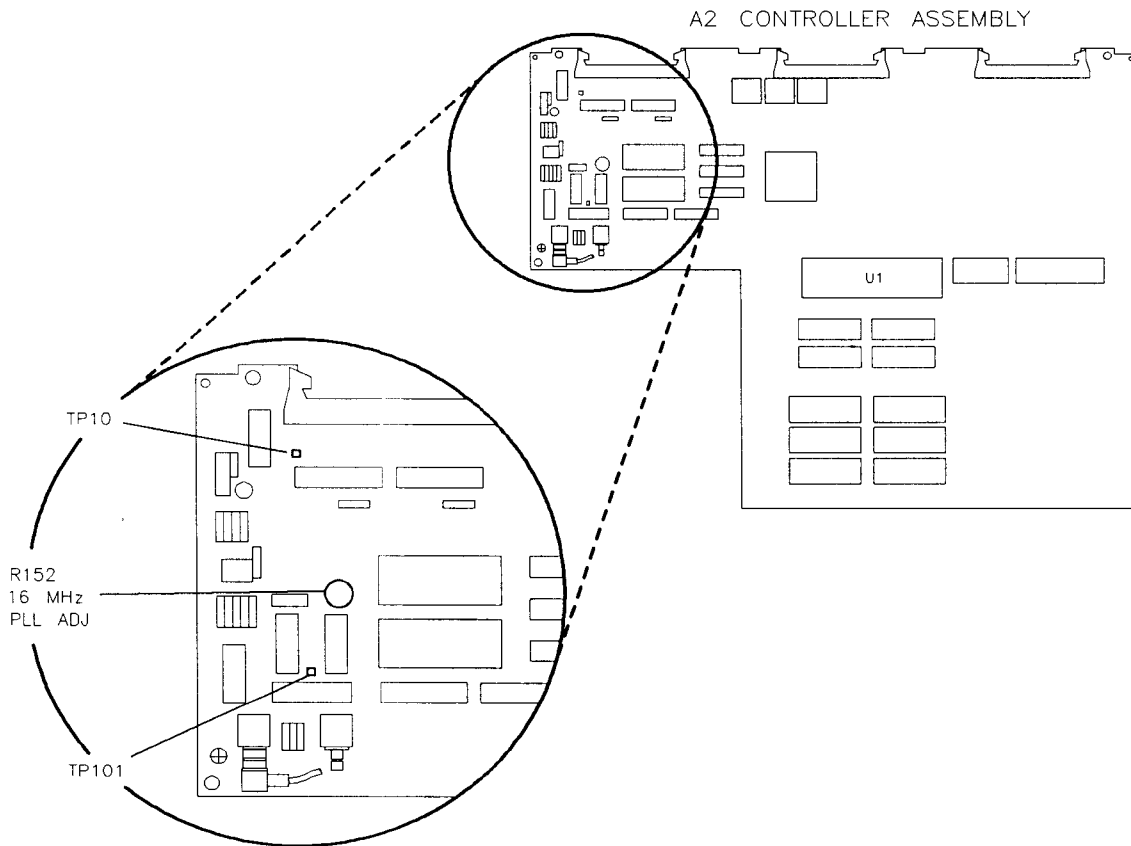

sj141e

Figure 3-8. 16 MHz PLL Adjustment Location

4. Set the spectrum analyzer **(LINE)** switch on. Wait until the spectrum analyzer's power-on adjustments have completed.
5. Set the microwave frequency counter as follows:
Sample rate Fully counterclockwise
10 Hz-500 MHz/500 MHz-26.5 GHz Switch 10 Hz-500 MHz
50 Ω /1 M Ω Switch 1 M Ω

6. Disconnect W22 (10 MHz frequency counter) from A2J8. The display will probably appear distorted and error messages may appear. Ignore the error messages.
7. Adjust A2R152 (16 MHz PLL ADJ) until the microwave frequency counter reads 14.4 MHz \pm 200 KHz.
8. Reconnect W22 to A2J8. The microwave frequency counter should read 16 MHz. If the counter reads 16 MHz and the display is still distorted, perform the display adjustments in the service guide, if necessary.
9. On the spectrum analyzer, press **CAL**, **REALIGN LO and IF** to clear any error messages.

Procedure 4. HP 8560E Frequency Response Adjustment

Assembly Adjusted

A15 RF Assembly

Related Performance Tests

Displayed Average Noise Level
Frequency Response

Description

A signal of the same known amplitude is applied to the spectrum analyzer at several different frequencies. At each frequency, the DAC controlling the flatness compensation amplifiers is adjusted to place the peak of the displayed signal at the same place on the screen. The preselector is centered at each frequency before setting the other DAC value. With firmware revisions greater than 920528, there are correction points at 2 MHz and 6 MHz. These points are outside the synthesized sweeper's frequency range. The DAC values for these two points are set to a fixed offset from the DAC value at 10 MHz. The DAC values are stored in EEROM.

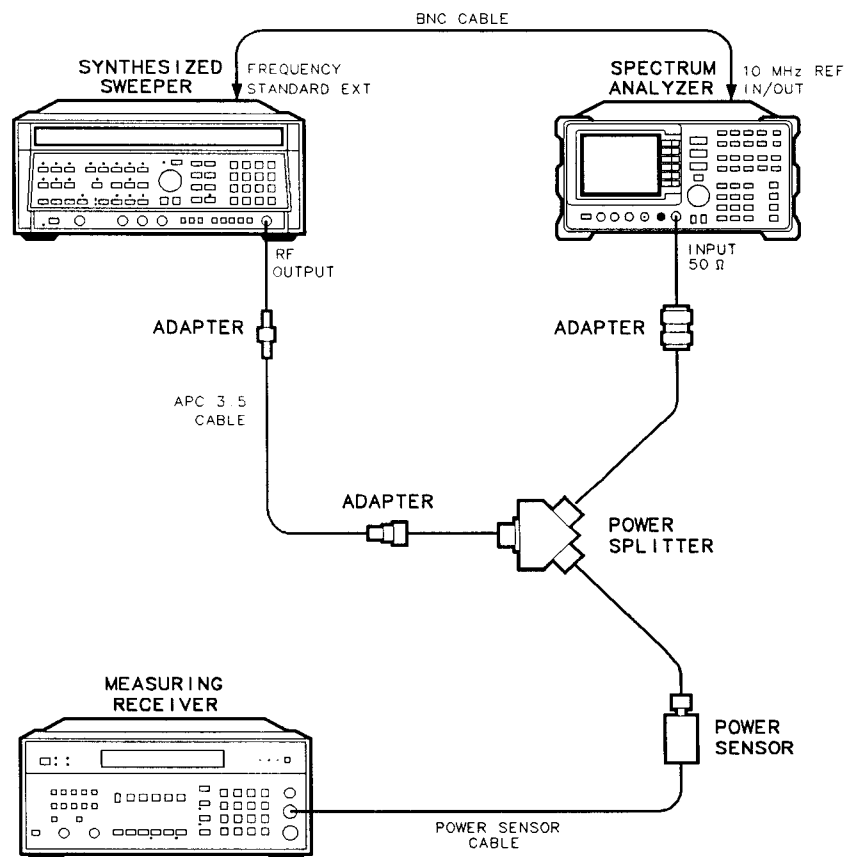

sj142e

Figure 3-9. Frequency Response Adjustment Setup

Equipment

Synthesized sweeper	HP 8340A/B
Measuring receiver	HP 8902A
Power sensor	HP 8482A
Power splitter	HP 11667A

Adapters

Type-N (m) to Type-N (m)	1250-1475
Type-N (m) to APC 3.5 (f)	1250-1744
Type APC 3.5 (f) to APC 3.5 (f)	5061-5311

Cables

BNC, 122 cm (48 in)	HP 10503A
APC 3.5, 91 cm (36 in)	8120-4921

Procedure

1. Connect the equipment as shown in Figure 3-9. Do not connect the HP 8482A power sensor to the HP 11667B power splitter.
2. Zero and calibrate the HP 8902A/HP 8482A combination in log mode (power levels read out in dBm) and connect the power sensor through an adapter to the power splitter.
3. Place the WR PROT/WR ENA jumper on the A2 controller assembly in the WR ENA position.
4. Press **PRESET** on the HP 8560E and set the controls as follows:

Center Frequency	10 MHz
Span	0 Hz
Resolution bandwidth	300 kHz
dB/division	2 dB
5. Press **INSTR PRESET** on the HP 8340A/B and set the controls as follows:

CW frequency	10 MHz
Power level	-4 dBm
6. On the HP 8560E, press **MKR** **CAL** **MORE 1 OF 2 SERVICE CAL DATA**, then **FLATNESS**. The current value of the RF gain DAC should be displayed in the active function area. If the frequency displayed in the active function area is not 10 MHz, press **↑** or **↓** until 10 MHz is displayed.
7. Enter the appropriate power sensor calibration factor into the HP 8902A.
8. Set the HP 8340A/B **CW** output to the frequency indicated in the active function area of the HP 8560E display. Adjust the HP 8340A/B power level for a -10 dBm reading on the HP 8902A.
9. On the HP 8560E spectrum analyzer, adjust the RF gain DAC value using the front-panel knob or keypad until the marker reads -10 dBm ±0.10 dB. Each DAC count yields an approximate 0.01 dB change.
10. On the spectrum analyzer, press **→** to proceed to the next frequency.
11. Repeat steps 7 through 10 for all low-band frequencies ≥10 MHz.
12. If the firmware revision is later than 920528, perform steps 13 through 17. Otherwise, skip to step 18.

13. Press **⇧** until 10 MHz is displayed in the active function block. Record the RF gain DAC value at 10 MHz.

10 MHz RF gain DAC value _____

14. Add 67 to the 10 MHz RF gain DAC value and record as the 2 MHz RF gain DAC value.

2 MHz RF gain DAC value _____

15. Add 62 to the 10 MHz RF gain DAC value and record as the 6 MHz RF gain DAC value.

6 MHz RF gain DAC value _____

16. Press **⇩** until 2 MHz is displayed in the active function block. Use the DATA keys to enter the 2 MHz RF gain DAC value recorded in step 14.

17. Press **⇧** until 6 MHz is displayed in the active function block. Use the DATA keys to enter the 6 MHz RF gain DAC value recorded in step 15.

18. Press **PREV MENU STORE DATA** , then **YES** on the HP 8560E.

19. Place the WR PROT/WR ENA jumper on the A2 controller assembly in the WR PROT position.

Procedure 5. HP 8561E Frequency Response Adjustment

Assembly Adjusted

A15 RF Assembly

Related Performance Tests

Displayed Average Noise Level
Frequency Response

Description

A signal of the same known amplitude is applied to the spectrum analyzer at several different frequencies. At each frequency, the DAC controlling the flatness compensation amplifiers is adjusted to place the peak of the displayed signal at the same place on the screen. The preselector is centered at each frequency before setting the other DAC value. With firmware revisions greater than 920528, there are correction points at 2 MHz and 6 MHz. These points are outside the synthesized sweeper's frequency range. The DAC values for these two points are set to a fixed offset from the DAC value at 10 MHz. The DAC values are stored in EEROM.

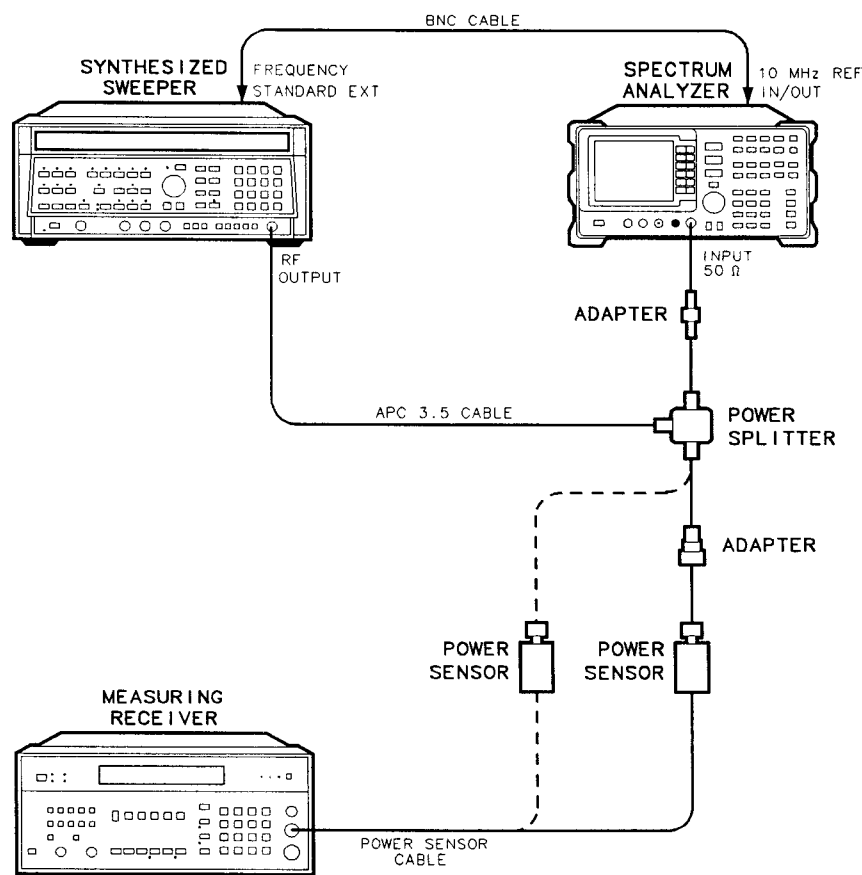

SK112

Figure 3-10. Frequency Response Adjustment Setup

Equipment

Synthesized Sweeper	HP 8340A/B
Measuring Receiver	HP 8902A
Power Sensor	HP 8482A
Power Sensor	HP 8485A
Power Splitter	HP 11667B

Adapters

Type-N (m) to Type-N (m)	1250-1475
Type-N (m) to APC 3.5 (m)	1250-1743
Type-N (f) to APC 3.5 (m)	1250-1750
Type APC 3.5 (f) to APC 3.5 (f)	5061-5311

Cables

BNC, 122 cm (48 in)	HP 10503A
APC 3.5, 91 cm (36 in)	8120-4921

Procedure

Note The YIG-tuned filter/mixer slope and offset adjustment must be correct before the high band part of the frequency response adjustment can be done.

1. Connect the equipment as shown in Figure 3-10. Do not connect the HP 8482A Power Sensor to the HP 11667B Power Splitter.
2. Zero and calibrate the HP 8902A/HP 8482A combination in log mode (power levels read out in dBm) and connect the power sensor through an adapter to the power splitter.
3. Place the WR PROT/WR ENA jumper on the A2 controller assembly in the WR ENA position. The jumper is on the edge of the A2 board assembly and can be moved without folding the board down.
4. Press **PRESET** on the HP 8561E and set the controls as follows:

Center frequency	10 MHz
Span	0 Hz
Resolution bandwidth	300 kHz
dB/division	2 dB
5. Press **INSTR PRESET** on the HP 8340A/B and set the controls as follows:

CW	10 MHz
POWER LEVEL	-4 dBm
6. On the HP 8561E, press **MKR** **CAL** **MORE 1 OF 2 SERVICE CAL DATA**, then **FLATNESS**. The current value of the RF Gain DAC should be displayed in the active function area.
7. Enter the appropriate power sensor calibration factor into the HP 8902A.
8. Set the HP 8340A/B **CW** output to the frequency indicated in the active function area of the HP 8561E display. Adjust the HP 8340A/B POWER LEVEL for a -10 dBm reading on the HP 8902A.
9. On the HP 8561E, adjust the RF Gain DAC value using the front-panel knob or keypad until the marker reads -10 dBm ±0.10 dB. Each DAC count results in an amplitude change of approximately 0.01 dB.
10. On the HP 8561E, press **↑** to proceed to the next frequency.

11. Repeat steps 7 through 10 for all low-band frequencies ≥ 10 MHz.
12. If the firmware revision is later than 920528, perform steps 13 through 17. Otherwise, skip to step 18.
13. Press \uparrow until 10 MHz is displayed in the active function block. Record the RF gain DAC value at 10 MHz.

10 MHz RF gain DAC value _____

14. Add 67 to the 10 MHz RF gain DAC value and record as the 2 MHz RF gain DAC value.

2 MHz RF gain DAC value _____

15. Add 62 to the 10 MHz RF gain DAC value and record as the 6 MHz RF gain DAC value.

6 MHz RF gain DAC value _____

16. Press \downarrow until 2 MHz is displayed in the active function block. Use the DATA keys to enter the 2 MHz RF gain DAC value recorded in step 14.
17. Press \uparrow until 6 MHz is displayed in the active function block. Use the DATA keys to enter the 6 MHz RF gain DAC value recorded in step 15.
18. Press **NEXT BAND** on the HP 8561E.
19. Disconnect the HP 8482A and its adapter from the HP 11667B. Connect the HP 8485A to the HP 8902A. Zero and calibrate the HP 8902A/HP 8485A combination. Connect the HP 8485A to the HP 11667B power splitter.
20. Enter the appropriate power sensor calibration factor into the HP 8902A.
21. Set the HP 8340A/B **CW** output to the frequency indicated in the active function area of the HP 8561E display.
22. Adjust the HP 8340A/B **POWER LEVEL** to place the signal midscreen on the HP 8561E display.
23. On the HP 8561E, press **PRESEL AUTO CTR**.
24. Adjust the HP 8340A/B **POWER LEVEL** for a -10 dBm reading on the HP 8902A.
25. On the HP 8561E, adjust the RF gain DAC value using the knob or keypad until the marker reads -10 dBm ± 0.10 dB.
26. On the HP 8561E, press \uparrow to proceed to the next frequency.
27. Repeat steps 21 through 27 for the remaining frequencies in Band 1.
28. Press **PREV MENU STORE DATA**, then **YES** on the HP 8561E.
29. Place the WR PROT/WR ENA jumper on the A2 controller assembly in the WR PROT position.

Procedure 6. HP 8563E Frequency Response Adjustment

Assembly Adjusted

A15 RF Assembly

Related Performance Tests

Displayed Average Noise Level
Frequency Response

Description

A signal of the same known amplitude is applied to the spectrum analyzer at several different frequencies. At each frequency, the DAC controlling the flatness compensation amplifiers is adjusted to place the peak of the displayed signal at the same place on the screen. The preselector is centered at each frequency before setting the DAC value. With firmware revisions greater than 920528, there are correction points at 2 MHz and 6 MHz. These points are outside the synthesized sweeper's frequency range. The DAC values for these two points are set to a fixed offset from the DAC value at 10 MHz. The DAC values are stored in EEROM.

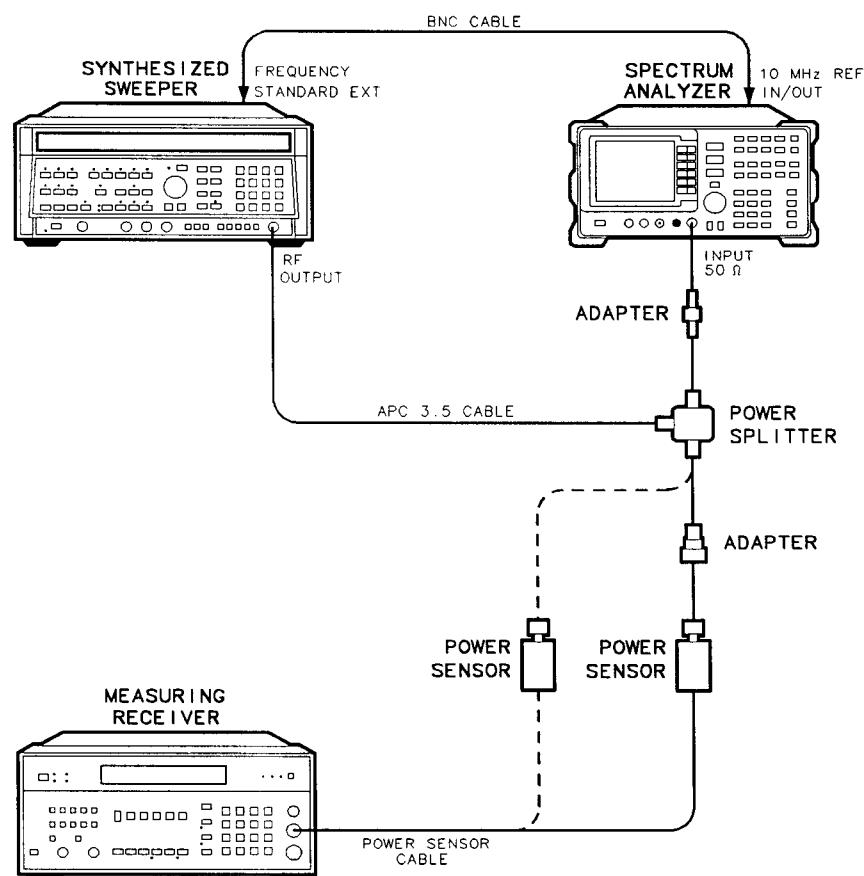

SK 112

Figure 3-11. Frequency Response Adjustment Setup

Equipment

Synthesized sweeper	HP 8340A/B
Measuring receiver	HP 8902A
Power sensor	HP 8482A
Power sensor	HP 8485A
Power splitter	HP 11667B

Adapters

Type-N (m) to Type-N (m)	1250-1475
Type-N (m) to APC 3.5 (m)	1250-1743
Type-N (f) to APC 3.5 (m)	1250-1750
Type APC 3.5 (f) to APC 3.5 (f)	5061-5311

Cables

BNC, 122 cm (48 in)	HP 10503A
APC 3.5, 91 cm (36 in)	8120-4921

Procedure

Note The YIG-tuned filter/mixer slope and offset adjustment must be correct before the high band part of the frequency response adjustment can be done.

1. Connect the equipment as shown in Figure 3-11. Do not connect the HP 8482A power sensor to the HP 11667B power splitter.
2. Zero and calibrate the HP 8902A/HP 8482A combination in log mode (power levels read out in dBm) and connect the power sensor through an adapter to the power splitter.
3. Place the WR PROT/WR ENA jumper on the A2 controller assembly in the WR ENA position. The jumper is on the edge of the A2 board assembly and can be moved without folding the board down.
4. Press **PRESET** on the HP 8563E and set the controls as follows:

Center frequency	10 MHz
Span	0 Hz
Resolution BW	300 kHz
dB/division	2 dB
5. Press **INSTR PRESET** on the HP 8340A/B and set the controls as follows:

CW frequency	10 MHz
Power level	-4 dBm
6. On the HP 8563E, press **MKR** **CAL** **MORE 1 OF 2 SERVICE CAL DATA**, then **FLATNESS**. The current value of the RF Gain DAC should be displayed in the active function area.
7. Enter the appropriate power sensor calibration factor into the HP 8902A.
8. Set the HP 8340A/B **CW** output to the frequency indicated in the active function area of the HP 8563E display. Adjust the HP 8340A/B POWER LEVEL for a -10 dBm reading on the HP 8902A.
9. On the HP 8563E, adjust the RF gain DAC value using the front-panel knob or keypad until the marker reads -10 dBm \pm 0.10 dB. Each DAC count results in an amplitude change of approximately 0.01 dB.
10. On the HP 8563E, press **↑** to proceed to the next frequency.

11. Repeat steps 7 through 10 for all low-band frequencies ≥ 10 MHz.
12. If the firmware revision is later than 920528, perform steps 13 through 17. Otherwise, skip to step 18.
13. Press \uparrow until 10 MHz is displayed in the active function block. Record the RF gain DAC value at 10 MHz.

10 MHz RF gain DAC value _____

14. Add 67 to the 10 MHz RF gain DAC value and record as the 2 MHz RF gain DAC value.

2 MHz RF gain DAC value _____

15. Add 62 to the 10 MHz RF gain DAC value and record as the 6 MHz RF gain DAC value.

6 MHz RF gain DAC value _____

16. Press \downarrow until 2 MHz is displayed in the active function block. Use the DATA keys to enter the 2 MHz RF gain DAC value recorded in step 14.
17. Press \uparrow until 6 MHz is displayed in the active function block. Use the DATA keys to enter the 6 MHz RF gain DAC value recorded in step 15.
18. Press **NEXT BAND** on the HP 8563E.
19. Disconnect the HP 8482A and its adapter from the HP 11667B. Connect the HP 8485A to the HP 8902A. Zero and calibrate the HP 8902A/HP 8485A combination. Connect the HP 8485A to the HP 11667B power splitter.
20. Enter the appropriate power sensor calibration factor into the HP 8902A.
21. Set the HP 8340A/B **CW** output to the frequency indicated in the active function area of the HP 8563E display.
22. Adjust the HP 8340A/B POWER LEVEL to place the signal midscreen on the HP 8563E display.
23. On the HP 8563E, press **PRESEL AUTO CTR**.
24. Adjust the HP 8340A/B POWER LEVEL for a -10 dBm reading on the HP 8902A.
25. On the HP 8563E, adjust the RF gain DAC value using the knob or keypad until the marker reads -10 dBm ± 0.10 dB.
26. On the HP 8563E, press \uparrow to proceed to the next frequency.
27. Repeat steps 21 through 27 for the remaining frequencies in band 1.
28. On the HP 8563E, press **NEXT BAND** to proceed to band 2.
29. Repeat steps 21 through 27 for the remaining frequencies in band 2.
30. On the HP 8563E, press **NEXT BAND** to proceed to band 3.
31. Repeat steps 21 through 27 for the remaining frequencies in band 3.
32. Press **PREV MENU STORE DATA**, then **YES** on the HP 8563E.
33. Place the WR PROT/WR ENA jumper on the A2 controller assembly in the WR PROT position.

** For HP Internal Reference Only **

Customer Order Number

Manufacturing Part Number

08564-90029



Printed in USA

November 1997